

FURRION

30 Amp POWER INLET

F30ITX-XX
F30INS-SS



Powersmart™
Voltage indicator



Powersmart™ 3-LED
bright blue power indicator

Snap lock rear cover for easy installation

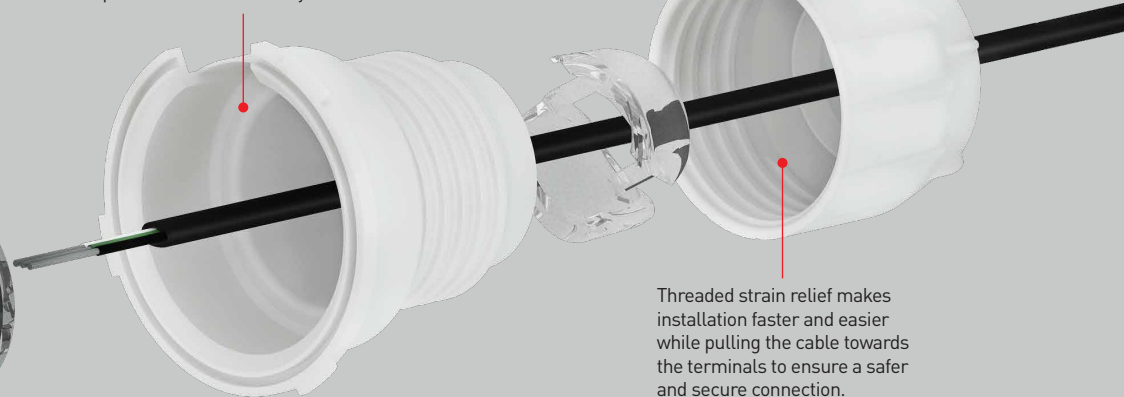

Threaded strain relief makes installation faster and easier while pulling the cable towards the terminals to ensure a safer and secure connection.

Innovative terminal design provides 50% more screw thread. Secure cable with more torque and reduce cross threading during installation.

Transparent pin face provides the user with quick indication that the cable is secured to the terminal and provides visible warning for overheating connection or internal damage.



Designed and tested to meet rigorous global industry standards including USCG, ABYC, CE and Marine ETL Listed.



F30ITS-PS



F30ITR-PS



F30INS-SS

UNIVERSAL FIT
WITH ALL OTHER BRANDS!

New, safe and innovative design reduces human error during installation and on OEM production lines. The unique and industry-first terminal design reduces operating temperature by up to 10°F.

- Furrion's Powersmart™ LED indicator
- Furrion's Sleek, modern design
- Available in polished stainless steel or fibre filled UV Polyester materials
- Universal fit for industry standards



F30ITX-XX / F30INS-SS | 30 Amp POWER INLET

F30ITS-XX

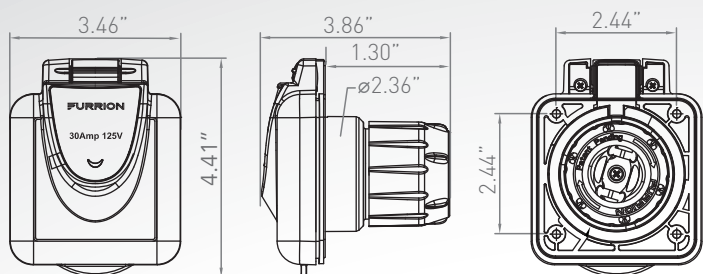

F30ITR-XX

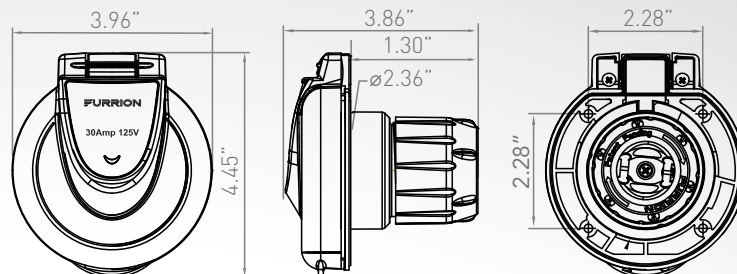

F30INS-SS

*Stainless steel inlet does not include LED

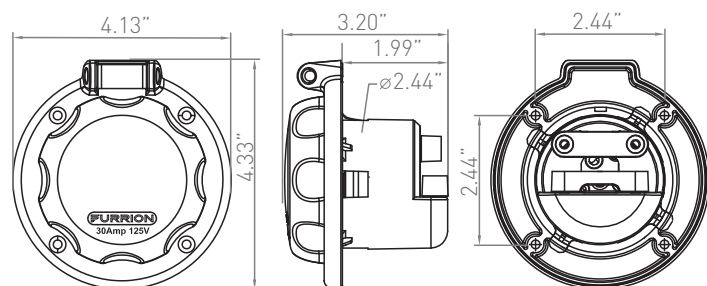

F30ITS-XX	F30ITS-PS -White
	F30ITS-BS -Black
	F30ITS-GS -Grey
F30ITR-XX	F30ITR-PS -White
	F30ITR-BS -Black
	F30ITR-GS -Grey

Specifications

Plastic inlet	
Logo plate	316 marine grade Stainless Steel
Outer casing	Fibre filled UV stabilized polyester
Stainless steel inlet	
Outer casing:	Hand polished 316L marine grade stainless steel

Rear and internal parts

Plug Inserts	PC (CTI greater than 600v)
Rear enclosure	PA - UL flammability rating 94v-0
Terminals and pins	Nickel plated brass pins for corrosion resistance
Tested to marine UL498 and CSA C22.2 Standards	

Product Packaging Information(F30ITX-XX)

Packaging type	Blister	Master Carton Box
Quantity per box	1	24
Carton Dimensions	5.75"x3.54"x 8.03"	15.75"x13.19"x19.29"
Carton Gross Weight (kg)	0.31	11.7
Carton Net Weight (kg)	0.25	6.0

Product Packaging Information (F30INS-SS)

Packaging type	Gift box	Master Carton Box
Quantity per box	1	24
Carton Dimensions	5.51"x3.50"x4.76"	18.11"x17.72"x12.80"
Carton Gross Weight (kg)	0.62	18.5
Carton Net Weight (kg)	0.51	12.2